

Effect of Chromium on the Surface Tension of Fe-C-Cr Model Alloys

Vliv chromu na povrchové napětí Fe-C-Cr modelových slitin

Mgr. Vlastimil Novák; doc. Ing. Lenka Řeháčková, Ph.D.; doc. Ing. Bedřich Smetana, Ph.D.; Ing. Lubomíra Drozdová; prof. Ing. Jana Dobrovská, CSc.

VŠB – Technical University of Ostrava, Faculty of Metallurgy and Materials Engineering, Regional Materials Science and Technology Centre, 17. listopadu 15/2172, Ostrava-Poruba, Czech Republic

The presented paper is focused on the experimental study of the surface tension of selected Fe-C-Cr model alloys. The surface tension was measured by the sessile drop method in the temperature interval from the melting point of the given model alloys to the temperature of 1,600°C. The effect of the temperature and the chemical composition on the surface tension of the model alloys was studied. Therefore, the model alloys with different chromium content (0.92 – 4.76 wt. %) were chosen for an examination of this influence. Experimental surface tension measurements were repeated for each sample and then statistically evaluated by statistical computing environment R (R Core Team (2018). R: A language and environment for statistical computing. R Foundation for Statistical Computing, Vienna, Austria. URL <https://www.R-project.org>) to assess the reproducibility of the measured data. During evaluation of the surface tension dependence on temperature, it has been shown that the surface tension of the alloys increased slightly with the increasing temperature, i.e. that the temperature coefficient of the surface tension $d\sigma/dT$ was positive. The positive character of the temperature coefficient can be attributed to the presence of the surface active elements, especially the sulphur, in the selected samples. It was found that the surface tension of the alloy samples also raised with the increasing chromium content.

Key words: Fe-C-Cr alloys; surface tension; sessile drop method; effect of chromium

Předložený příspěvek je zaměřen na experimentální studium povrchového napětí vybraných Fe-C-Cr modelových slitin. Povrchové napětí vybraných slitin bylo měřeno pomocí jedné z kontaktních metod – metodou ležící kapky v pozorovací vysokoteplotní trubkové peci Clasic. Daná měření probíhala v teplotním intervalu od teploty likvidy modelové slitiny do teploty 1600 °C během ohřevu s rychlostí 5 °C·min⁻¹. Jednotlivé modelové slitiny byly během experimentu v kontaktu s vysoce čistým Al₂O₃ (korundovým) substrátem. Byl studován především vliv teploty a chemického složení na povrchové napětí. Pro vyšetřování vlivu chromu byly vybrány modelové slitiny, které se vzájemně lišily jeho obsahem. Obsah chromu ve vyšetřovaných slitinách se pohyboval v intervalu 0,92 – 4,76 hm. %. Z důvodu reprodukovatelnosti naměřených dat byla jednotlivá experimentální měření povrchového napětí vždy pro konkrétní vzorek několikrát opakována a poté statisticky vyhodnocena. Statistické analýzy byly uskutečněny prostřednictvím počítačového programu R (R Core Team (2018). R: A language and environment for statistical computing. R Foundation for Statistical Computing, Vienna, Austria. URL <https://www.R-project.org>). Při posouzení závislosti povrchového napětí na teplotě se ukázalo, že povrchové napětí daných slitin mírně vzrůstá s rostoucí teplotou a teplotní koeficient povrchového napětí $d\sigma/dT$ je pozitivní. Tento jev lze přičíst obsahu povrchově aktivních prvků, především síry ve vybraných vzorcích. Pozitivní charakter teplotního koeficientu povrchového napětí se projevil nejvýrazněji u vzorků 2 – 4, jejichž obsah povrchově aktivních prvků (kyslík, síra) byl nejvyšší. Zde povrchové napětí statisticky významně vzrůstalo s rostoucí teplotou (celkový F-test, p-hodnota $\ll 0,010$). Takřka konstantní závislost na teplotě se projevila u vzorku 5, který obsahoval nejméně povrchově aktivních prvků. Statisticky vyhodnocen byl také vliv obsahu chromu na povrchové napětí, který se ukázal jako statisticky významně odlišný (Kruskal-Wallisův test, p-hodnota $\ll 0,001$). Bylo pozorováno, že povrchové napětí zkoumaných vzorků se s rostoucím obsahem chromu zvyšuje.

Klíčová slova: Fe-C-Cr slitiny; povrchové napětí; metoda ležící kapky; vliv chromu

The surface tension of Fe-alloys is one of the essential parameters that influence the steel processes. The knowledge of this thermophysical quantity leads to a better insight to various phenomena associated with refining, casting, welding processes including the separation of inclusions from steel to slag, spreading of inclusions in slag and others. However, its experimental determination is usually complicated, time-consuming, costly, and it also brings practical difficulties that make it

more challenging. Mainly, methodological differences in experimental procedures between different laboratories and research groups are a significant source of discrepancy in the determination. There are several very different surface tension measurements techniques, for example, the sessile drop, maximum bubble pressure, pendant drop, capillary rise and levitation methods (electromagnetic, electrostatic and aerodynamic levitation). Presently, many thermodynamic and empirical

models for the calculation of a given quantity exist. Nonetheless, not all models can be used for multi-component systems in wide temperature and concentration range [1, 2]. Therefore, experimental data are irreplaceable.

In principle, the surface tension or surface energy arise from a phenomenon that atoms near a free surface have partially empty coordination shells, which require higher energy states than the atoms in the bulk of the solution. In a multicomponent alloy, atoms energy state of which is affected least by the surface, are segregated to the surface region, and this reduces the magnitude of the surface energy. Elements such as oxygen, sulphur, selenium are among the strongly surface-active elements in metallic melts. They markedly influence surface tension due to their low solubility [3 – 5].

Moreover, elements like chromium and other metallic alloying elements can also affect the surface tension, although to a lesser degree. It is because they possess smaller magnitudes of the energy changes associated with their segregation.

Regarding the effect of chromium, it has already been investigated by several researchers. However, a scientific standpoint on whether to include chromium among surface-active elements is vague. Trefyakova et al. investigated the dependence of surface tension on chromium content (up to 1 wt. % Cr) in Fe-Cr-O systems. In this case, the minimum surface tension occurred when the melt was the most microheterogeneous. The presence of chromium increased surface tension due to its ability to penetrate between the clusters, which made the melt more uniform [6]. The influence of chromium on surface tension was also investigated by Li and Mukai [7, 8]. They found that chromium slightly increases surface tension. Further, the chromium possesses a strong affinity to oxygen and facilitates its adsorption.

Therefore, at higher concentrations (above 10 wt. %) oxygen lowers the surface tension of Fe-Cr-O systems [9].

The presented work is focused on the experimental study of temperature and concentration dependencies of the surface tension of selected Fe-C-Cr model alloys with different chromium content. The surface tension was determined by the sessile drop method when the molten alloy was in contact with the alumina substrate.

1. Experimental

1.1 Samples preparation

Five model alloys (samples 1 – 5) were selected and used for experimental measurement of the surface tension by the sessile drop method. The chemical composition of chosen alloys is shown in Tab. 1. From the given alloys, samples of the diameter 5 mm, height 5 mm and weight approximately 0.7 g were prepared. Each sample was thoroughly mechanically polished before the experiment to remove surface oxides and then purified in acetone.

Tab.1 Chemical composition of the investigated alloys before experimental trials (wt. %)

Tab.1 Chemické složení zkoumaných slitin před experimentem (hm. %)

Sample	Cr	C	O	S	Mn	W	Co
1	0.924	0.344	0.0021	0.0675	0.056	–	0.013
2	1.925	0.345	0.0187	0.0521	0.049	0.015	0.020
3	2.970	0.342	0.0195	0.0522	0.050	0.024	0.020
4	3.772	0.335	0.0167	0.0545	0.053	0.028	0.014
5	4.760	0.340	0.0015	0.0062	0.042	0.044	0.010

Contents of other elements (Ni, Si, Ti, Mo, P, Al, Cu and Zr) present in alloys were below 0.005 wt. %. The rest was represented by iron.

The high purity Al₂O₃ (99.8 %) plate (37.3 × 44.7 × 2.0 mm) was used as a substrate (a non-wettable plate) in this study. Each Al₂O₃ plate was annealed at the temperature of 1150°C for 6 hours. The surface was cleaned with acetone, dried and used without touching the surfaces to avoid possible contamination.

1.2 Measurement of surface properties

Experimental determination of surface tension by the sessile drop method was carried out in the observation high-temperature tube furnace Clasic (Fig. 1). The temperature range has been set from the melting point of the alloy to the temperature of 1600°C. The method is based on automatic recognition of the geometric shape of a liquid metal sessile drop, which is in contact with a non-wetting surface.

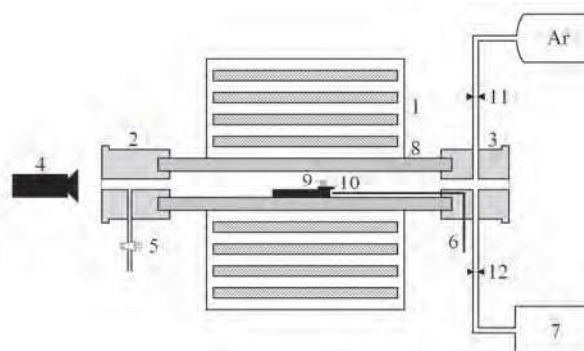

Fig. 1 Schematic illustration of the observation furnace Clasic
1) heating elements, 2) front flange, 3) rear flange, 4) CCD camera, 5) high-vacuum stopcock, 6) type B thermocouple, 7) vacuum pump, 8) alumina tube, 9) sample, 10) alumina substrate, 11) gas inlet, 12) gas outlet

Obr. 1 Schématické zobrazení pozorovací pece Clasic
1) topné elementy, 2) přední příruba, 3) zadní příruba, 4) CCD kamera, 5) vakuový ventil, 6) termočlánek typu B, 7) vakuová pumpa, 8) korundová trubice, 9) vzorek, 10) korundová podložka, 11) přívod plynu, 12) odvod plynu

Shapes of experimental drops were fitted to the solution of the Laplace-Young equation. This Laplace's method uses the global information provided by the shape of the investigated object.

Prepared sample (alloy/ Al_2O_3 substrate) was placed in the workspace of the furnace, which was hermetically sealed and then evacuated to approximately 0.1 Pa and washed with argon (> 99.9999%). This step was repeated several times. The heating rate was $5^\circ\text{C}\cdot\text{min}^{-1}$, and the maximum reached temperature measured by a thermocouple Pt-13 % Rh/Pt was $1,600^\circ\text{C}$. The experiment was carried out under an inert atmosphere of argon to prevent oxidation of the sample during measurement. The images of the forming process of the metallic melt drop during heating were captured by the camera CANON EOS 550D and then saved in the PC. The statistical analysis of surface tension measurements was carried out by the computing environment R (R Development Core Team, 2018).

2. Results and discussion

The temperature dependencies of the surface tension of examined Fe-alloys samples were measured successively to confirm the repeatability of the results and to assure their statistical evaluation. Figs. 1–5 show the dependencies of the surface tension on temperature for individual samples, each measured three times. The linear model is represented by a solid line. Besides, the figures contain a plot of confidence interval which covers with a 95 % reliability the expected mean surface tension observed at a given temperature and a 95 % prediction interval, at which the surface tension (individual observation) is located with 95 % reliability at a given temperature (dotted line).

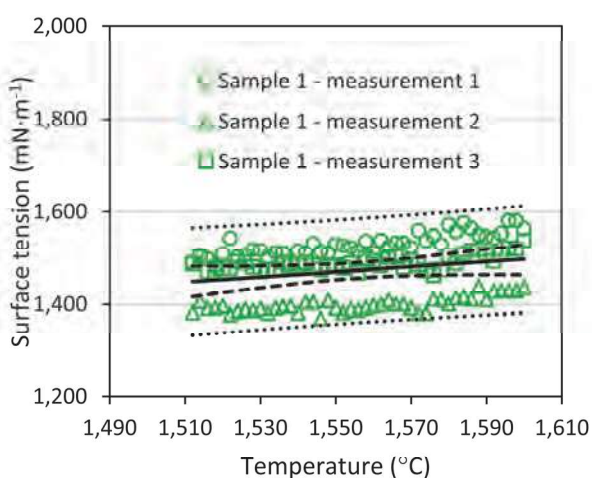

Fig. 2 Temperature dependencies of the surface tension for the sample 1 (0.924 wt. % Cr)

Obr. 2 Teplotní závislosti povrchového napětí pro vzorek 1 (0,924 hm. % Cr)

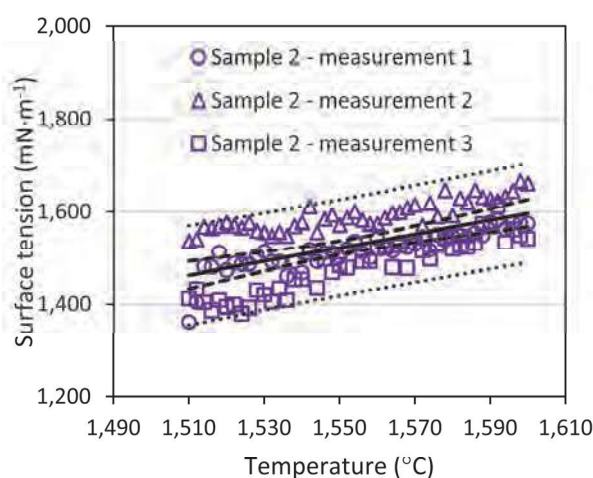

Fig. 3 Temperature dependencies of the surface tension for the sample 2 (1.925 wt. % Cr)

Obr. 3 Teplotní závislosti povrchového napětí pro vzorek 2 (1,925 hm. % Cr)

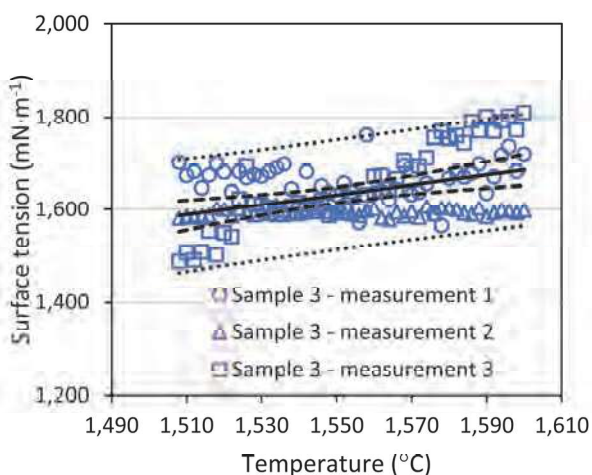

Fig. 4 Temperature dependencies of the surface tension for the sample 3 (2.970 wt. % Cr)

Obr. 4 Teplotní závislosti povrchového napětí pro vzorek 3 (2,970 hm. % Cr)

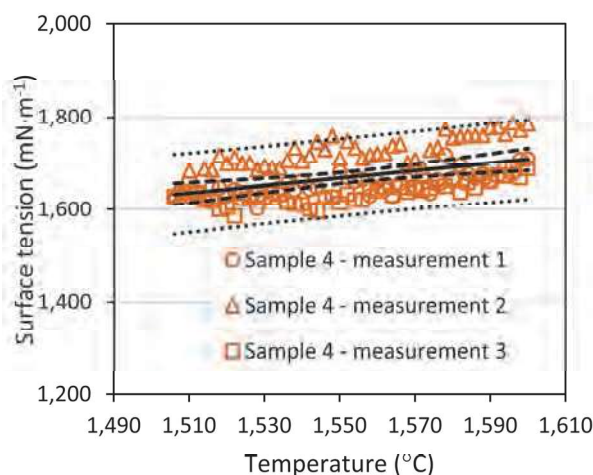

Fig. 5 Temperature dependencies of the surface tension for the sample 4 (3.772 wt. % Cr)

Obr. 5 Teplotní závislosti povrchového napětí pro vzorek 4 (3,772 hm. % Cr)

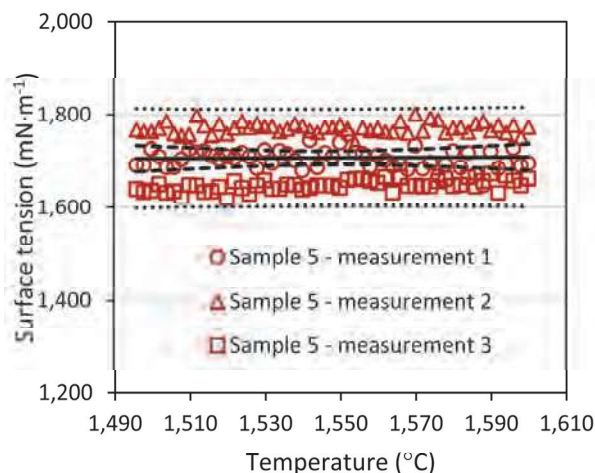

Fig. 6 Temperature dependencies of the surface tension for the sample 5 (4.760 wt. % Cr)

Obr. 6 Teplotní závislosti povrchového napětí pro vzorek 5 (4,760 hm. % Cr)

The normality of the measured data was verified by the Shapiro-Wilk test, which showed that the measured data were not normally distributed.

Tab.2 Statistical evaluation of the surface tension dependencies on temperature

Tab.2 Statistické vyhodnocení závislosti povrchového napětí na teplotě

Sample	$\sigma = f(T); \sigma \text{ (mN}\cdot\text{m}^{-1}), T \text{ (}^\circ\text{C)}$	F-test (p-value)
1	$\sigma(T) = 1,451 + 5.14 \cdot 10^{-1} \cdot (T - 1,512)$	0.007
2	$\sigma(T) = 1,463 + 1.48 \cdot (T - 1,510)$	<<0.001
3	$\sigma(T) = 1,586 + 1.10 \cdot (T - 1,508)$	<<0.001
4	$\sigma(T) = 1,633 + 8.01 \cdot 10^{-1} \cdot (T - 1,506)$	<<0.001
5	$\sigma(T) = 1,706 + 3.34 \cdot 10^{-2} \cdot (T - 1,496)$	0.807

The models 1–4 were statistically significant at the significance level of 5 % according to overall F-test (Tab. 2). For the sample 5 with the chromium content of 4.76%, the statistically significant influence of temperature on the surface tension was not observed (overall F-test, p-value 0.807). The surface tension, regardless of temperature, was around 1,707 mN·m⁻¹. The table also contains the equations of the surface tension dependence on temperature, which are valid in the measured temperature intervals.

Fig. 7 summarizes previous figures and shows the dependencies of the average surface tension of individual samples on temperature. From the figure, it is evident that the surface tension increases with the increasing temperature, and therefore the coefficient of surface tension $d\sigma/dT$ is positive for all observed samples. A positive coefficient of surface tension can be explained according to [10] where, based on the Gibbs adsorption theory, the free surface of a metal droplet is covered by a monolayer of surface active elements (sulphur, oxygen) with a lower surface tension than the volume phase itself.

With the increasing temperature, the surface-active elements are desorbed into the bulk of the liquid metal causing a slight increase in surface tension. This phenomenon was described for samples with higher sulphur content [11], and it is the most conspicuous at the samples 2–4, which possess the highest content of surface active elements. The minimum can be observed in the sample 5, which contains the fewest of these elements.

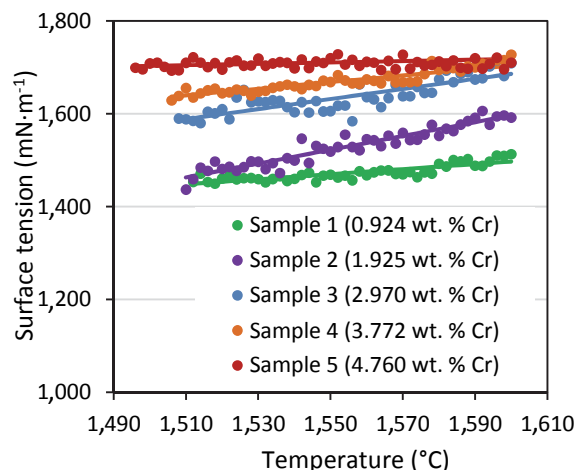

Fig. 7 Dependencies of average surface tension on the temperature for the samples 1 – 5

Obr. 7 Závislosti průměrného povrchového napětí na teplotě pro vzorky 1 – 5

The influence of chromium content on surface tension was analyzed by the Kruskal-Wallis test. Further, the effect was statistically significant because the p-value was <<0.001. The differences in surface tension were statistically significant at all observed chromium levels. This result is also illustrated by the box plot (Fig. 8).

As it can be seen from the figure, the surface tension of the examined samples increased with the increasing content of chromium assuming that surface tension dependencies on temperature are of no practical significance.

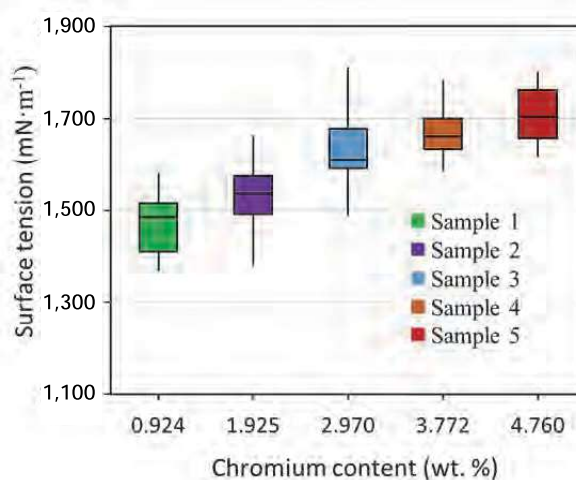

Fig. 8 Boxplot of chromium effect on the surface tension

Obr. 8 Krabicový graf znázorňující vliv chromu na povrchové napětí

Conclusions

The surface tension of three Fe-C-Cr alloys, varying in chromium content, was measured in the temperature range from the liquid temperature to 1,600°C with the following results:

- The temperature coefficient of surface tension ($d\sigma/dT$) was always positive for all samples. The obtained linear models were statistically significant at the significance level of 5 % except for the sample 5.
- The alloys composition had an impact on the values of quantities in question. The presence of sulphur and oxygen played a crucial role in this regard. This influence was particularly noticeable at the samples with higher content of these elements (2, 3 and 4) where the maximum values of the temperature coefficient of the surface tension were reached. Further, a markedly inferior content of oxygen lowered this quantity in the sample 1. On the temperature dependence of surface tension of the sample 5, it remained almost constant in the measured temperature range because of the lowest content of the surface active elements.
- The chromium content increased the values of the surface tension. This influence was confirmed by the Kruskal-Wallis test (p -value $\ll 0.001$). Further, the Dunn's test showed that no two samples had comparable surface tension (p -values $\ll 0.001$).
- Because the interaction between the melt and substrate was examined by only one of the contact methods, the obtained results will be supplemented by SEM and EDX analyzes to achieve a deeper understanding of the influence of composition and temperature on the surface tension of these model alloys.

Acknowledgements

This paper was created within the frame of the project No. LO1203 "Regional Materials Science and Technology

Centre - Feasibility Program" funded by the Ministry of Education, Youth and Sports of the Czech Republic.

References

- [1] EGRY, I., RICCI, E., NOVAKOVIC, R., OZAWA, S. Surface Tension of Liquid Metals and Alloys – Recent Developments. *Advances in Colloid and Interface Science*, 159 (2010) 2, 198–212.
- [2] CHEN, L., LEE, J. H., CHEN, C. F. On the Modeling of Surface Tension and its Applications by the Generalized Interpolation Material Point Method. *Computer Modeling in Engineering and Sciences*, 66 (2012) 6, 199–224.
- [3] McNALLAN, M., DEBROY, T. Effect of Temperature and Composition on Surface Tension in Fe-Ni-Cr Alloys Containing Sulfur. *Metallurgical Transactions B*, 22 (1991) 4, 557–560.
- [4] MOROHOSHI, K., UCHIKOSHI, M., ISSHIKI, M., FUKUYAMA, H. Effects of carbon and oxygen on Fe-C-O melt surface tension. *ISIJ International*, 53 (2013) 8, 1315–1319.
- [5] OZAWA, S., MOROHOSHI, K., HIBIYA, T. Influence of Oxygen Partial Pressure on Surface Tension of Molten Type 304 and 316 Stainless Steels Measured by Oscillating Droplet Method Using Electromagnetic Levitation. *ISIJ International*, 54 (2014) 9, 2097–2103.
- [6] TRET'YAKOVA, E.E., KLIMENKOV, E.A., BAUM, B.A., TYAGUNOV, G.V. Influence of Chromium on Surface Tension of Iron with Various Oxygen Contents. *Steel in the USSR*, 15 (1985) 8, 391–392.
- [7] LI, Z., ZEZE, M., MUKAI, K. Surface Tension and Wettability of Liquid Fe-16mass% Cr-S Alloy with Alumina. *Materials Transactions*, 44 (2003) 10, 2108–2113.
- [8] MUKAI, K., LI, Z., ZEZE, M. Surface Tension and Wettability of Liquid Fe-16mass% Cr-O alloy with alumina. *Materials Transactions*, 43 (2002) 7, 1724–1731.
- [9] YOSHIKAWA, T., YAMAMOTO, K., TANAKA, T., MORITA, K. Consideration on Effects of Surface-Active Components on Surface Tensions of Molten Alloys. *Journal of High Temperature Society*, 32 (2006) 5, 289–294.
- [10] DUBBERSTEIN, T., HELLER, H., KLOSTERMANN, J., SCHWARZE, R., BRILLO, J. Surface tension and density data for Fe-Cr-Mo, Fe-Cr-Ni, and Fe-Cr-Mn-Ni steels. *Journal of Materials Science*, 50 (2015) 22, 7227–7237.
- [11] LI, Z., MUKAI, K., ZEZE, M., MILLS, K. C. Determination of the Surface Tension of Liquid Stainless Steel. *Journal of Materials Science*, 40 (2005) 9, 2191–2195.

Na Vysoké škole báňské – Technické univerzitě Ostrava byla podepsána smlouva na modernizaci HPC systémů pro IT4Innovations národní superpočítačové centrum

Na VŠB – Technické univerzitě Ostrava byla v listopadu 2018 podepsána smlouva na modernizaci HPC systémů pro IT4Innovations národní superpočítačové centrum. Jedná se o rozšíření klastru Anselm a dodá jej společnost Atos IT Solutions and Services, s.r.o. Superpočítač bude mít nově teoretický výkon přesahující 800 teraflopů za sekundu, bude tedy více než 8krát výkonnější než jeho předchůdce, který byl spuštěn v roce 2013. Výpočetní kapacity systémů, které provozuje IT4Innovations, jsou v rámci grantových soutěží k dispozici celé vědecké komunitě České republiky. Termín dodání nového stroje je duben 2019.

V náročném soutěžním dialogu, jehož vítězem se stala firma Atos, byl kladen důraz nejen na cenu, ale také na použití nejvyspělejších momentálně dostupných technologií. Čeští vědci tak získají přístup k nejmodernější generaci procesorů Intel a také k nejvýkonnějším GPU akceleratorům od firmy NVIDIA.

„Poptávka českých vědců po výpočetních zdrojích převyšuje naši momentální dostupnou kapacitu zhruba o 100 %. Tato modernizace navýší naše kapacity a pomůže nám tento problém řešit. Čeští vědci současně dostanou k dispozici stroj s nejmodernějšími technologiemi, což jim umožní si tyto technologie osvojit a držet tak krok se světem,“ vysvětlil Vít Vondrák, ředitel IT4Innovations.

– z tiskové zprávy –